



CNC Grinding Center Model NEXT

High-precision tool grinding machine



Highest precision with a small footprint

Resulting from 30+ years of experience in the grinding field of drills, end mills, form cutters and gear cutting tools.

Continuity in Kinematics - Refined and optimized in the details

Stability, accuracy and reliability are the most important attributes for the NEXT model. Due to particularly short set-up times, NEXT is very suitable for small or large batches that have long cycle times where high quality is guaranteed. An extensive array of accessories is available for your production needs (e.g. tailstock, steady rest, shank guide, HF spindles, push-on and turning units), allowing gear cutting tools, blades, punches and inserts to be produced. In an automatic mode of grinding, drills and milling-type tools are easily managed without difficulty. Due to the new placement of the automatic loading unit, the footprint is relatively a square consisting of 4m².

Dynamics: The previous and proven TTB drive concept of a calibrated preload and hydrodynamically lubricated axes integrated into the new NEXT has been further optimized.

By doubling the rapid traverse speed and incorporating a newly developed direct-drive swivelling axis, the productivity result of the machine is increased even more.

The U axis can be equipped with belt drive or, as option, with direct drive.

PM (Predictive Maintenance) System: The Monitoring and control of integrated temperature and vibration sensors allow the highest quality of tools to ever be produced.

A new energy concept brings with it a lower overall heat input. Thus, reducing the warm-up and stabilization period of the machine to reach the initial operating temperature. Using the data from the WebVisu, predictive maintenance can be easily customized to Customer liking.

HP transmission: The new power transmission concept results in increased power that is transferred to the spindles with simultaneous vibration reduction. This allows the production of tools up to Ø14 mm (Ø9/16") without any limitations.

The grinding wheel turret has an indexing accuracy of only 1/3 of a micron. It is equipped with up to 5 spindles, and with each spindle capable of having up to 4 grinding wheels.

The grinding wheel turret is still the core component of the NEXT.

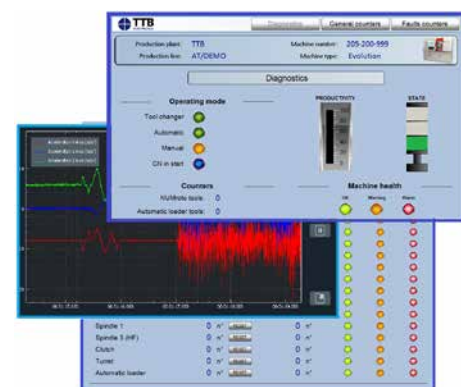

Opening Up New Markets With The **Next TTB Machine**

Tools with diameters between 0.02mm and 14 mm can be manufactured in perfect quality. The resharpener of tools up to $\text{\O}25$ mm is also effective without any issues.

Tools:

- Hobs, shaper cutters and power skiving (gearing)
- End Mill Cutters
- Form Cutters
- Drills, step drills
- Taps
- Turning tools
- Cutting blades
- Indexable inserts
- Stamps, punching tools
- Burrs



Flexible Extension Options

A wide range of options

Various versions of tool collets, chucking systems, grinding spindles and grinding wheel adapters are available for the NEXT. This means that the NEXT can be individually configured and optimally adapted to fit Customer needs. Replacing the modular components is also quick and easy. The tool probe is always part of the standard equipment. The grinding wheels can be dressed, regenerated and measured in the machine, even during automatic production mode.

Steady Rest v3 System

The fully automatic steady rest is designed for tools having grind lengths in the range of 10x to 15x of the diameter. The radial mounting position of the steady rest can be adjusted in 15 ° increments, this in order to find the optimal position. Assembly and set-up are achieved quickly by a simple procedure and with fewer steps. The support prisms and bushings are clamped by a quick clamping system and can be aligned according to the tool taper.



Shaft Guide System

The shaft guide system optimizes the concentricity of the tools, especially tools that possess a somewhat short shank length. A support bushing is used as the primary centering device, while an opposing finger clamps the opposite side to apply pressure to keep it seated into the support bushing. The finger support can be oriented on the left or right side and is equipped with a support bushing.



Removable Tailstock

The dismountable tailstock is used in the production and regrinding of hobs, shaper cutters and reamers. In case of hobs, it is used in combination with a 6th axis. Tools can be held between centers or with a collet. The positioning of the tailstock (back mounting) is done by high precision needle bearings. The tailstock can also be used with the automatic loading of such tools. The precise clamping pressure is adjustable.



Solutions for almost every need

6th Axis (Tilting of the Grinding Wheels)

The W-axis (also called 6th axis) can tilt the grinding wheel turret in the range of $\pm 15^\circ$ degrees. For the manufacturing of hobs, this sets the angle of attack of the grinding wheel to the pitch angle of the cutter. The axis is equipped with a brake and a high-precision encoder. The grinding of ballnose cutters with 6th axis is also possible.

Turret with 4 or 5 Grinding Spindles

The turret can optionally be supplied with 4 or 5 spindle positions. Short or long spindles with steel or ceramic bearings can be used, depending on the grinding operation. The exchange of a spindle can be done in less than two minutes. High frequency spindles of 60,000, 100,000 and 150,000 RPM can also be adapted.

iC-Detect - Camera Unit for Orientation of the Internal Coolant Holes

iC-Detect camera unit is installed in the clean side (loading unit compartment). As it is integrated into the loading cycle, the measuring/alignment process occurs simultaneously while grinding the tools. The camera unit allows the automatic alignment of internal coolant holes of various shapes all the way down to 0.05mm diameter.

Industry 4.0

Several variations are available for integrating the NEXT machine into an Industry 4.0 system. TTB creates the optimal solution together with the Customer.

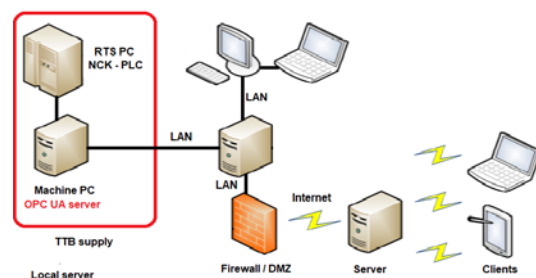
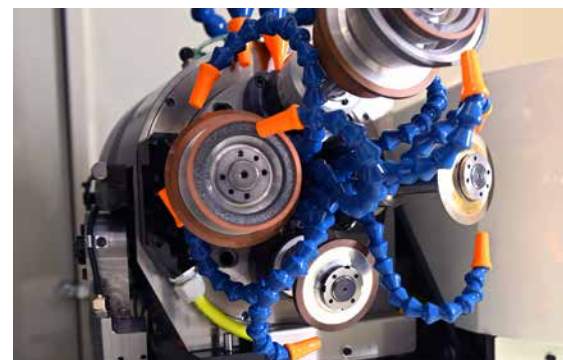

Automation

Oriented towards flexibility and profitability

Loader with short cycle time and high capacity

Thanks to the newly developed loader, automatic loading time has been **extremely improved**. For this purpose, the new double gripper clamps round shafts from 1 to 16mm.

The standard version of the loader has 2 pallets for 1-16 mm. Optionally, 3 or 4 pallets is also possible. Depending on the shank diameter, the pallets can hold up to 814 tools. Specific solutions such as special pallets or special loading operations can be provided upon request.

System solutions

Additional units for dressing, sorting, ejecting, turning, etc. are also available. This allows tools such as knives, turning and grooving tools, indexed tools, punches, flow drills to be produced efficiently and precisely.

Numroto programming system

The programs for the NEXT model are prepared with the flexible and proven NUMROTOplus® programming system.

Peripheral devices

TTB also offers many systems such as coolant filtration, chillers, oil mist, fire protection, measuring, balancing and loading systems.

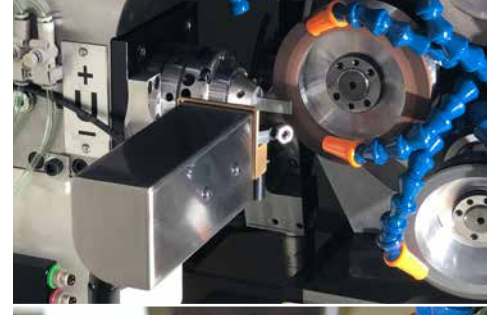
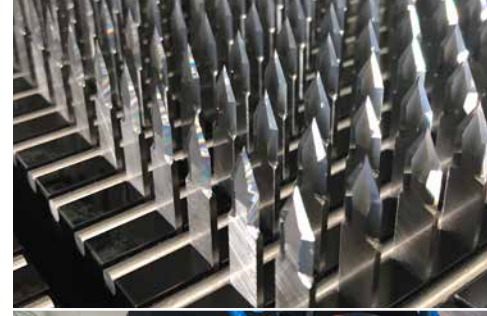
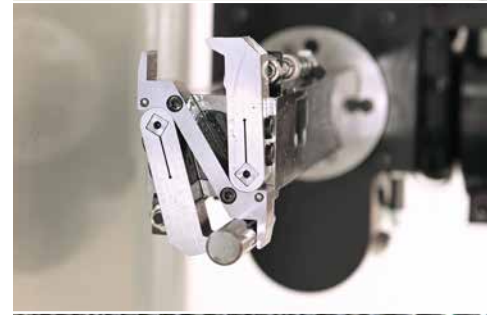
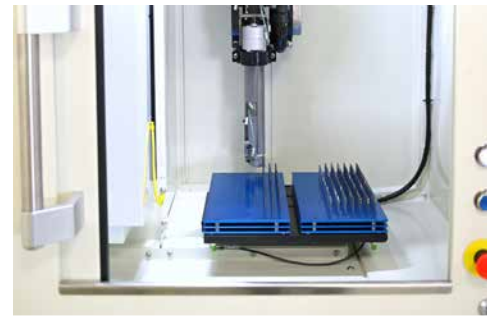

Technical Specifications

Linear Axes	
Longitudinal Travel (X Axis)	290 mm
Cross Travel (Y Axis)	250 mm
Vertical Travel (Z Axis)	155 mm
Swiveling Axis	
Swiveling Range of Workhead (V Axis)	270 °
Swiveling Range of the Turret (W Axis) Option	+/-15°
Rotary Axes	
Rotation Range of Workhead (U Axis)	infinite
Rotary Speed (U Axis) for cylindrical grinding	0 – 1.500 1/min
Feedrates	
Linear Axes (X, Y, Z Axes)	6 m/min
Swivel of Tool Spindle (V Axis)	36.000 °/min
Rotary speed of U Axis as a positioning Axis	72.000 °/min
Minimum Positioning Increment	
Linear Axes (X, Y, Z Axes)	0,0001 mm
Rotary Axes (U, V)	0,0001°
Measuring systems	
Resolution Linear Axes (X, Y, Z Axes)	0,01 µ
Accuracy Swivel Axis (V Axis)	+/- 2"
Accuracy Rotary Axis (U Axis)	+/- 20"
Turret and Wheel Grinding Spindles	
Number of Grinding Wheel Spindles (HSK C32)	4 (or 5 Option)
Nominal power grinding motor (Pn-S1)	10,0 kW
Programmable Speed of Grinding Spindles	Up to 12.000 1/min
Number of possible Wheels per Spindle	1 – 3
Positioning Time of Turret	2 sec.
High Frequency Spindles	60/100/150.000 1/min
Tool Clamping	
Clamping Systems	W25, W20, B15 Hydraulic Collet
Clamping Diameter Range	1 – 25,4 mm
Clamping Length	Up to 250 mm
Optional Clamping Systems	Upon request
Application Technology	
Grinding from Solid Material	Ø 0,02 – 14 mm
Resharpener	Ø 3 – 25 mm
Grinding Length	max. 150 mm
CNC Control	
	NUM
Dimensions of Machine (see layout above)	200 x 200 x 218 cm
Weight (approx.)	3.500 kg

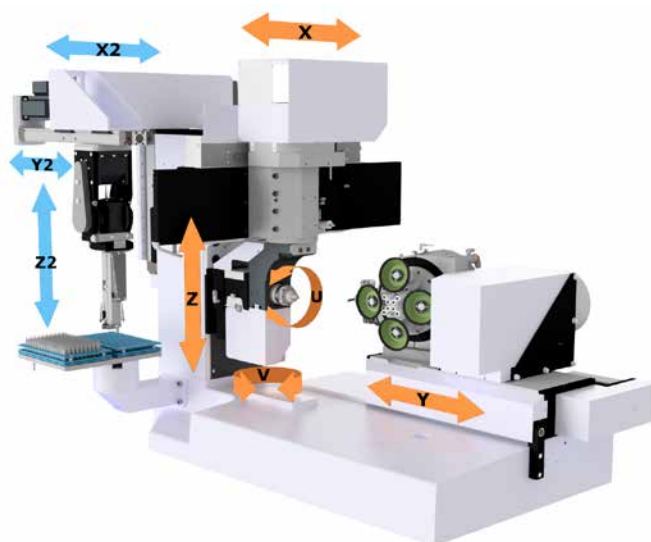
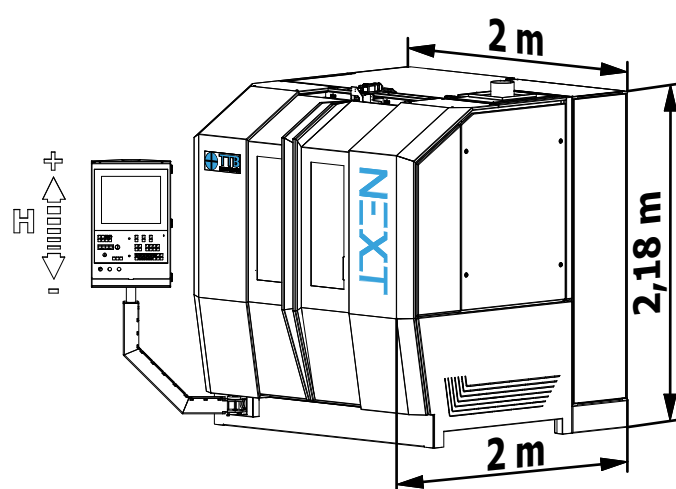

We reserve the right to make changes to the product delivered compared with the data and illustrations in this catalogue.



TTB Engineering SA
Via Industria 9
CH-6826 Riva S. Vitale
Phone (+41) 91 / 640 20 30
www.ttb-eng.com
info@ttb-eng.com

